







Part List

DB21-3

Unit: inch

No	Picture	Specification	Qty
A		Screw Ø3*1/2"	62
B		L Bracket	6
C		Drawer Glides	6
D		Glide Connector	6
E		Corner Bracket	4
F		Metal Clip	4
G		Bumper	12

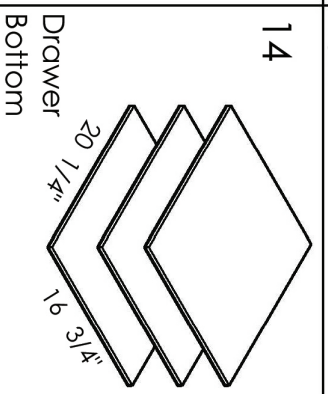
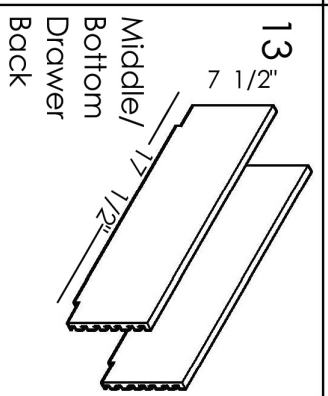
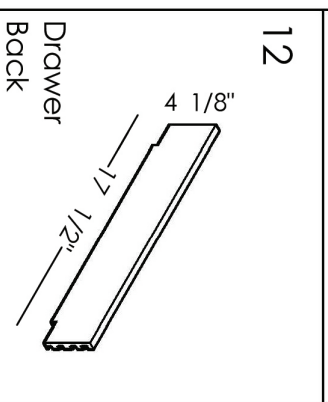
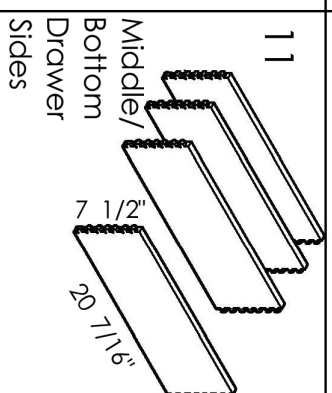
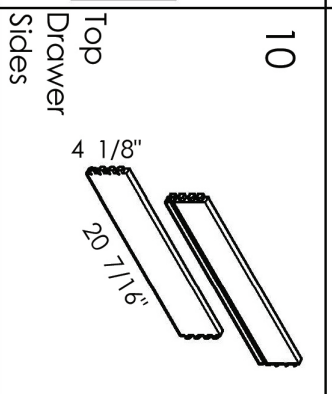
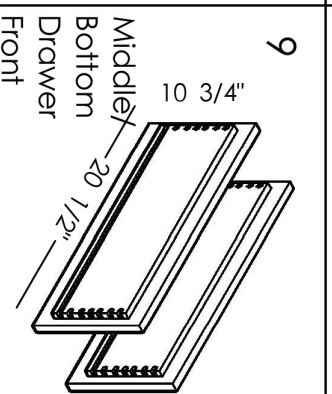
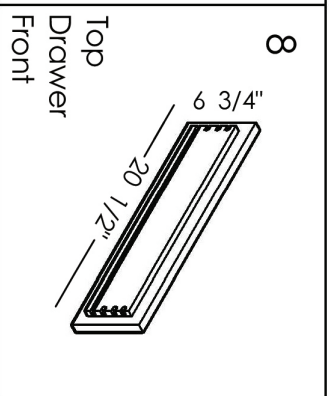
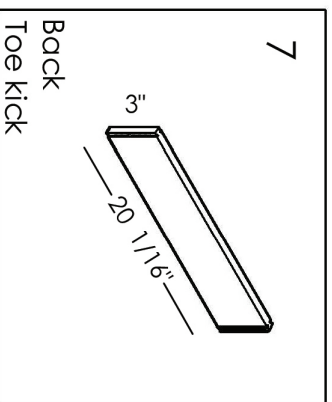
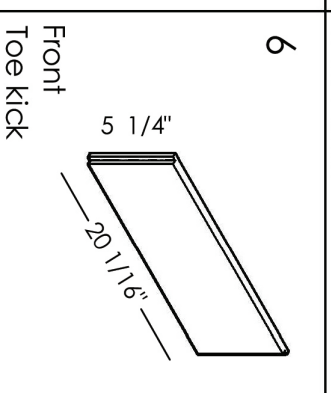
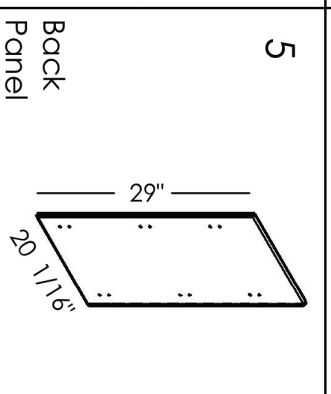
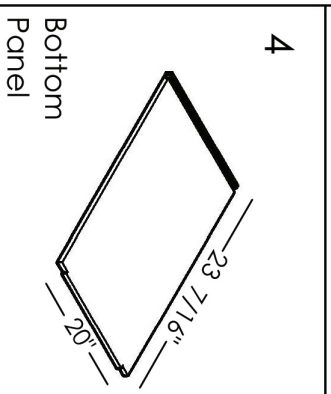
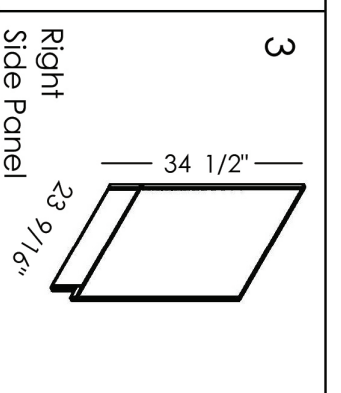
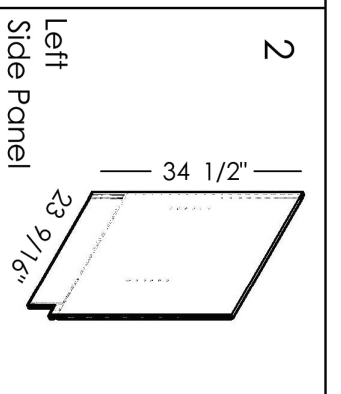
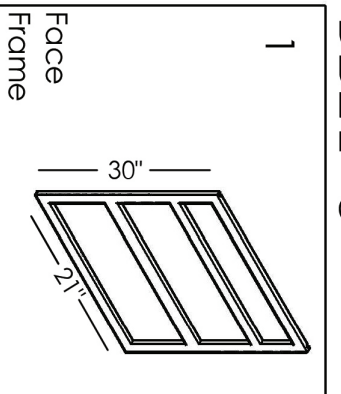

Step 1

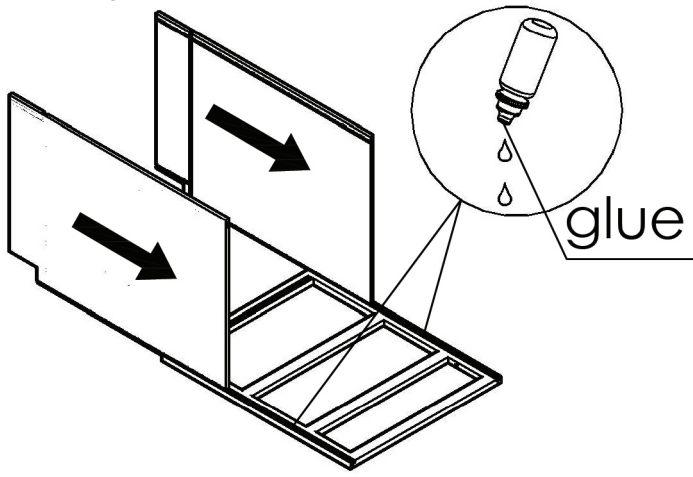

1. Place the face frame face down. Place a bead of glue in the dovetail groove. Slide the left and right sides into the vertical grooves (holes inward). Wipe away any excess glue.

Step 2

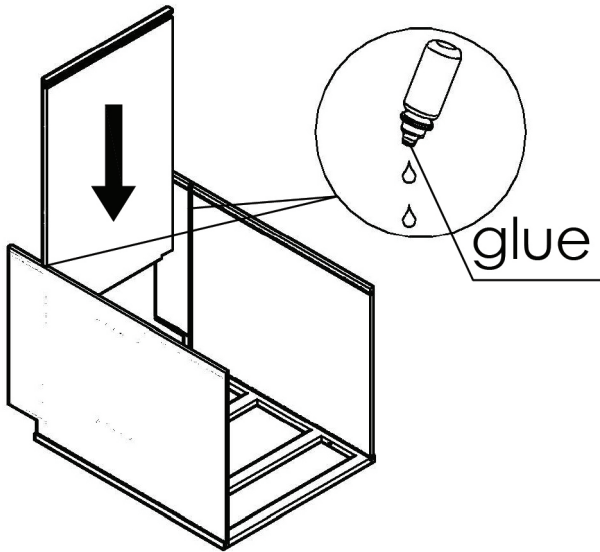

2. Slide floor board into the parallel grooves on the walls. Make sure the floor board notch fits into the grooves on the face frame. Make sure the groove on the floor board is inward toward the inside of the cabinet.

Step 3

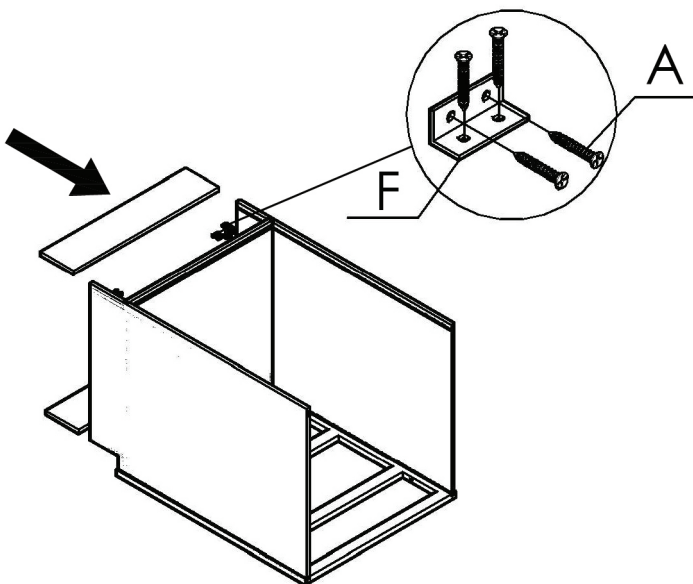

3. Place the small toe kick into the grooves below the floor board on the back side of the cabinet (opposite of face) paint side out. Slide the large toe kick into the grooves below the floor board on the front side. Place one metal clip on the inside of each corner below the floor board. This will connect the large and small toe kicks to the left and right sides of the cabinet.

Step 4

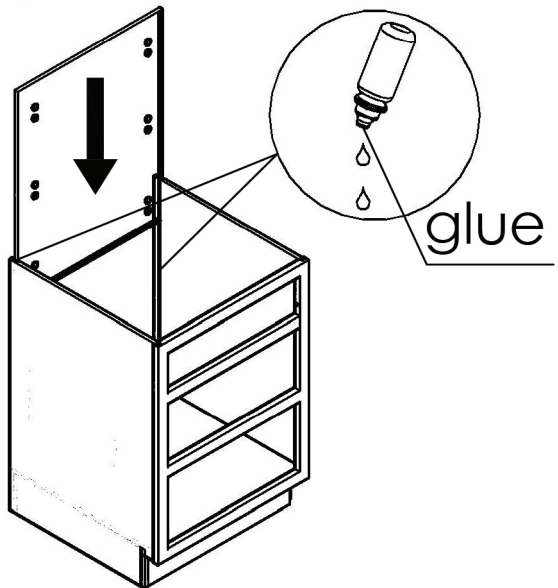

4. Flip the cabinet upright and slide the back wall into the parallel grooves on the back side of the cabinet (finished side inward). Be sure to slide it into the grooves on the floor board.

Step 5

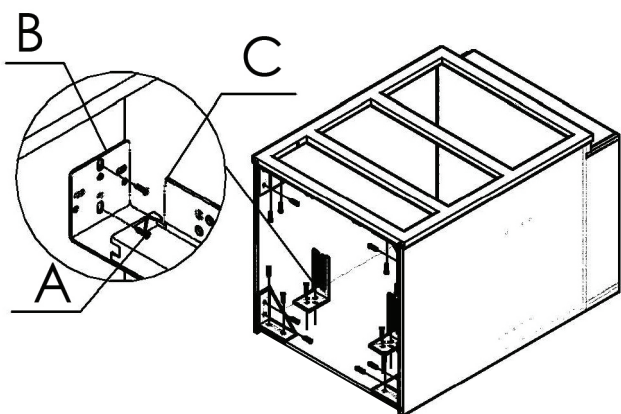

5. Locate L brackets and match the holes on the brackets to the corresponding holes on the inside of the back wall. Use small screws to attach them to the cabinet. There are six L brackets in total.

Step 6

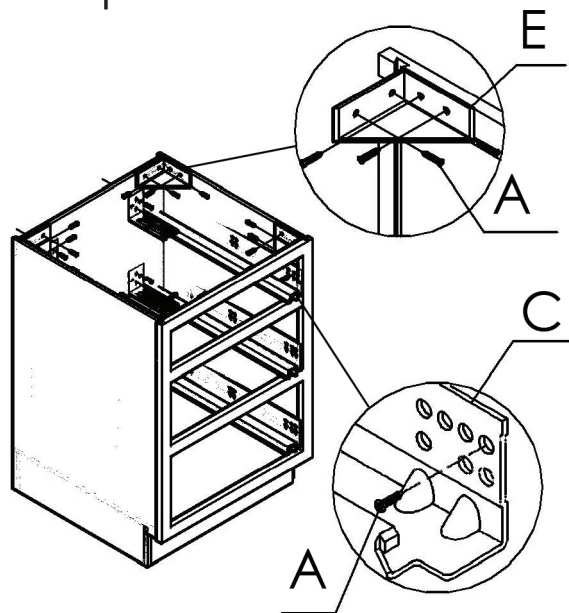

6. Place one corner bracket into each corner on the inside of the cabinet. This will secure the face frame and back wall to the left and right sides of the cabinet.

Locate the left and right drawer glides. Slide the back of the glide into the notches on the corresponding L brackets (located on back wall). The front of the glide should rest on the inside of the face frame. Secure it to the inside of the face using the pre-drilled dimple.

Step 7

1.

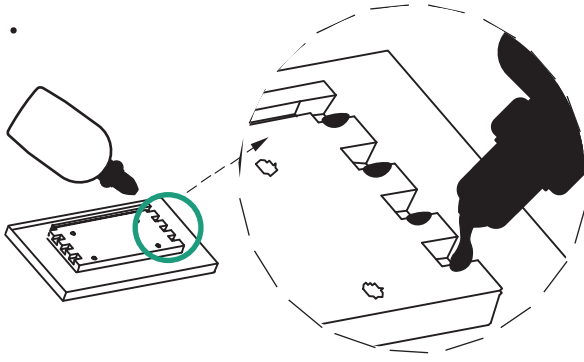

7-1. Set the drawer front face down. Place a dab of glue in each tooth.

2.

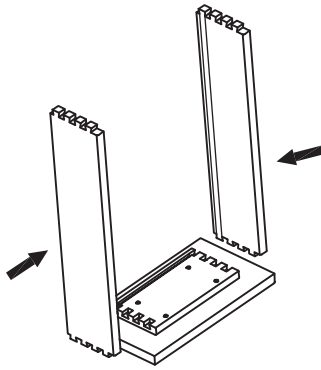

7-2. Using a rubber mallet lightly pound each drawer side into place. Line up the teeth and the grooves on the drawer front to the teeth and grooves on each side (grooves inward).

3.

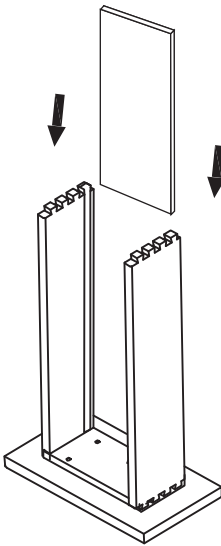

7-3. Slide the drawer floor into the parallel grooves on the inside of the drawer. Make sure it fits into the groove on the drawer front. Be sure to wipe off any excess glue.

4.

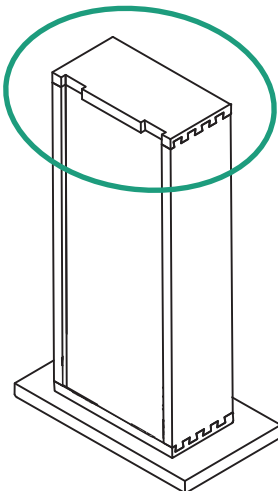

7-4. Place the drawer back (notch side down) teeth inward between the left and right sides of the drawer walls. Interlock the teeth. Lightly pound it into place using a rubber mallet.

Step 8

1.

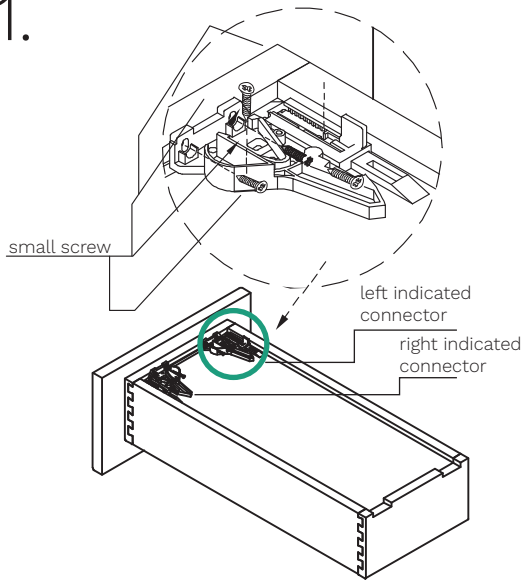

8-1. Locate the right and left glide connectors. Place them on the under side of the drawer (triggers inward) and secure them to the drawer front, side, and floor using four small screws per connector.

Be sure to place one rubber bumper on each side of the back of drawer face.

2.

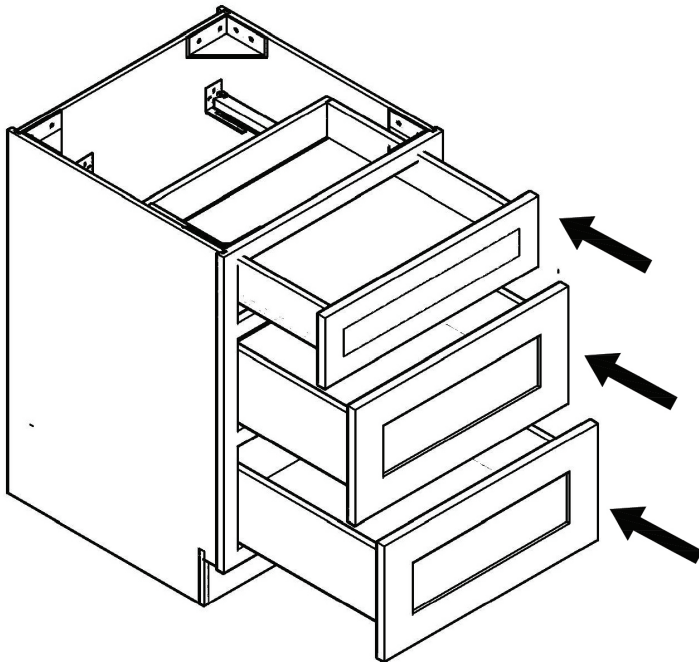

8-2. Slide your completed drawer into the cabinet until the glides click into place securing the drawer.

Completed

